

TDA7056A

3 W BTL mono audio output amplifier with DC volume control

3 W BTL mono audio output amplifier with DC volume control

TDA7056A

FEATURES

- DC volume control
- Few external components
- Mute mode
- Thermal protection
- Short-circuit proof
- No switch-on and off clicks
- Good overall stability
- Low power consumption
- Low HF radiation
- ESD protected on all pins.

GENERAL DESCRIPTION

The TDA7056A is a mono BTL output amplifier with DC volume control. It is designed for use in TV and monitors, but also suitable for battery-fed portable recorders and radios.

Missing Current Limiter (MCL)

A MCL protection circuits is built-in. The MCL circuit is activated when the difference in current between the output terminal of each amplifier exceeds 100 mA (typical 300 mA). This level of 100 mA allows for headphone applications (single-ended).

QUICK REFERENCE DATA

SYMBOL	PARAMETER	CONDITIONS	MIN.	TYP.	MAX.	UNIT
V_P	positive supply voltage range		4.5	–	18	V
P_O	output power	$R_L = 16 \Omega$; $V_P = 12 V$	3	3.5	–	W
G_v	voltage gain		34.5	35.5	36.5	dB
ϕ	gain control range		75	80	–	dB
I_P	total quiescent current	$V_P = 12 V$; $R_L = \infty$	–	8	16	mA
THD	total harmonic distortion	$V_P = 0.5 W$	–	0.3	1	%

ORDERING INFORMATION

EXTENDED TYPE NUMBER	PACKAGE			
	PINS	PIN POSITION	MATERIAL	CODE
TDA7056A	9	SIL	plastic	SOT110

Note

1. SOT110-1; 1996 August 21.

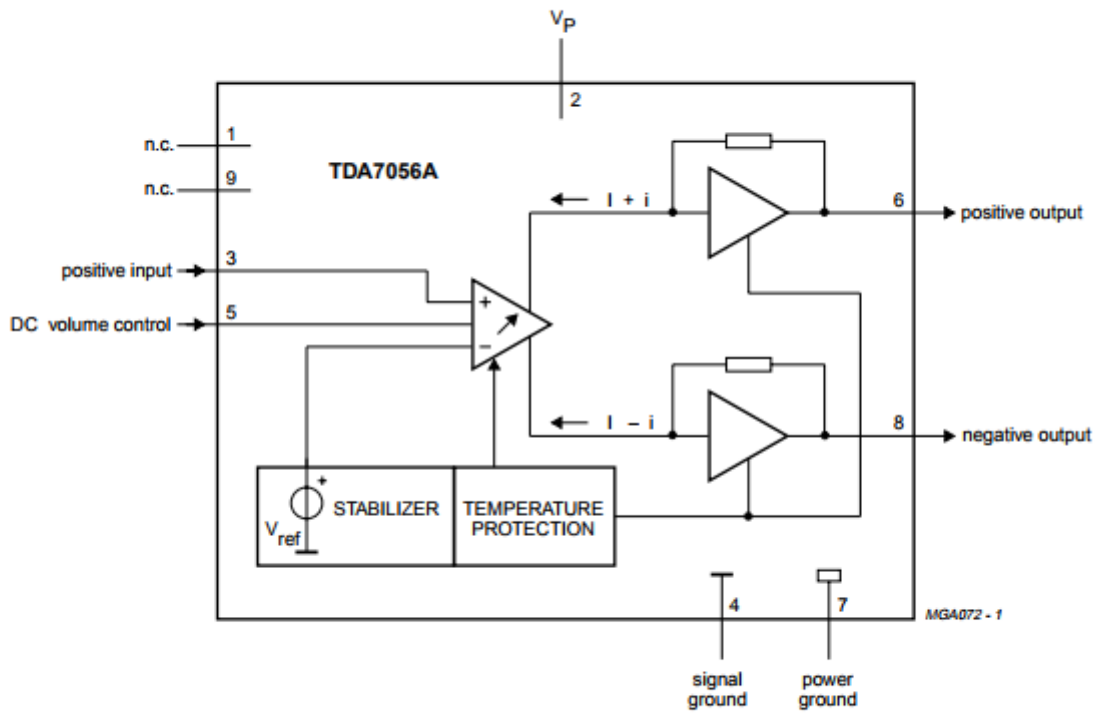

Fig.1 Block diagram.

PINNING

SYMBOL	PIN	DESCRIPTION
n.c.	1	not connected
V_P	2	positive supply voltage
V_I	3	voltage input
GND1	4	signal ground
VC	5	DC volume control
OUT+	6	positive output
GND2	7	power ground
OUT-	8	negative output
n.c.	9	not connected

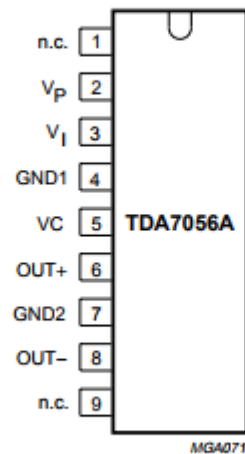

Fig.2 Pin configuration.

FUNCTIONAL DESCRIPTION

The TDA7056A is a mono BTL output amplifier with DC volume control, designed for use in TV and monitor but also suitable for battery-fed portable recorders and radios.

In conventional DC volume circuits the control or input stage is AC coupled to the output stage via external capacitor to keep the offset voltage low.

In the TDA7056A the DC volume stage is integrated into the input stage so that coupling capacitors are not required and a low offset voltage is maintained.

At the same time the minimum supply voltage remains low.

The BTL principle offers the following advantages:

- lower peak value of the supply current
- the frequency of the ripple on the supply voltage is twice the signal frequency

Thus, a reduced power supply and smaller capacitors can be used which results in cost savings.

For portable applications there is a trend to decrease the supply voltage, resulting in a reduction of output power at conventional output stages. Using the BTL principle increases the output power.

The maximum gain of the amplifier is fixed at 35.5 dB. The DC volume control stage has a logarithmic control characteristic.

The total gain can be controlled from 35.5 dB to -44 dB.

If the DC volume control voltage is below 0.3 V, the device switches to the mute mode.

The amplifier is short-circuit proof to ground, V_P and across the load. A thermal protection circuit is also implemented. If the crystal temperature rises above +150 °C the gain will be reduced, thereby reducing the output power.

Special attention is given to switch-on and off clicks, low HF radiation and a good overall stability.

LIMITING VALUES

In accordance with the Absolute Maximum System (IEC 134).

SYMBOL	PARAMETER	CONDITIONS	MIN.	MAX.	UNIT
V_P	supply voltage range		-	18	V
I_{ORM}	repetitive peak output current		-	1.25	A
I_{OSM}	non repetitive peak output current		-	1.5	A
P_{tot}	total power dissipation	$T_{case} < 60\text{ °C}$	-	9	W
T_{amb}	operating ambient temperature range		-40	+85	°C
T_{stg}	storage temperature range		-55	+150	°C
T_{vj}	virtual junction temperature		-	+150	°C
T_{sc}	short-circuit time		-	1	hr
V_3	input voltage pin 3		-	8	V
V_5	input voltage pin 5		-	8	V

THERMAL RESISTANCE

SYMBOL	PARAMETER	THERMAL RESISTANCE
$R_{th\ j-a}$	from junction to ambient in free air	55 K/W
$R_{th\ j-c}$	from junction to case	10 K/W

Note to the thermal resistance

$V_P = 12\text{ V}$; $R_L = 16\ \Omega$; The maximum sine-wave dissipation is = 1.8 W. The $R_{th\ j-a}$ of the package is 55 K/W;

$$T_{amb\ (max)} = 150 - 55 \times 1.8 = 51\text{ °C}$$

CHARACTERISTICS

$V_P = 12\text{ V}$; $f = 1\text{ kHz}$; $R_L = 16\ \Omega$; $T_{\text{amb}} = 25\text{ }^\circ\text{C}$; unless otherwise specified (see Fig.6)

SYMBOL	PARAMETER	CONDITIONS	MIN.	TYP.	MAX.	UNIT
V_P	positive supply voltage range		4.5	–	18	V
I_P	total quiescent current	$V_P = 12\text{ V}$; $R_L = \infty$; note 1	–	8	16	mA
Maximum gain ($V_S = 1.4\text{ V}$)						
P_O	output power	THD = 10%; $R_L = 16\ \Omega$	3	3.5	–	W
		THD = 10%; $R_L = 8\ \Omega$	–	5.2	–	W
THD	total harmonic distortion	$P_O = 0.5\text{ W}$	–	0.3	1	%
G_V	voltage gain		34.5	35.5	36.5	dB
V_I	input signal handling	$V_S = 0.8\text{ V}$; THD < 1%	0.5	0.65	–	V
$V_{\text{no(rms)}}$	noise output voltage (RMS value)	$f = 500\text{ kHz}$; note 2	–	210	–	μV
B	bandwidth	at –1 dB	–	20 Hz to 300 kHz	–	
SVRR	supply voltage ripple rejection	note 3	38	46	–	dB
$ V_{\text{off}} $	DC output offset voltage		–	0	150	mV
Z_I	input impedance pin 3		15	20	25	k Ω
Minimum gain ($V_S = 0.5\text{ V}$)						
G_V	voltage gain		–	–44	–	dB
$V_{\text{no(rms)}}$	noise output voltage (RMS value)	note 4	–	20	30	μV
Mute position						
V_O	output voltage in mute position	$V_S \leq 0.3\text{ V}$; $V_I = 600\text{ mV}$	–	–	30	μV
DC volume control						
ϕ	gain control range		75	80	–	dB
I_S	control current	$V_S = 0\text{ V}$	60	70	80	μA

Notes to the characteristics

1. With a load connected to the outputs the quiescent current will increase, the maximum value of this increase being equal to the DC output offset voltage divided by R_L .
2. The noise output voltage (RMS value) at $f = 500\text{ kHz}$ is measured with $R_S = 0\ \Omega$ and bandwidth = 5 kHz.
3. The ripple rejection is measured with $R_S = 0\ \Omega$ and $f = 100\text{ Hz}$ to 10 kHz. The ripple voltage of 200 mV (RMS value) is applied to the positive supply rail.
4. The noise output voltage (RMS value) is measured with $R_S = 5\text{ k}\Omega$ unweighted.

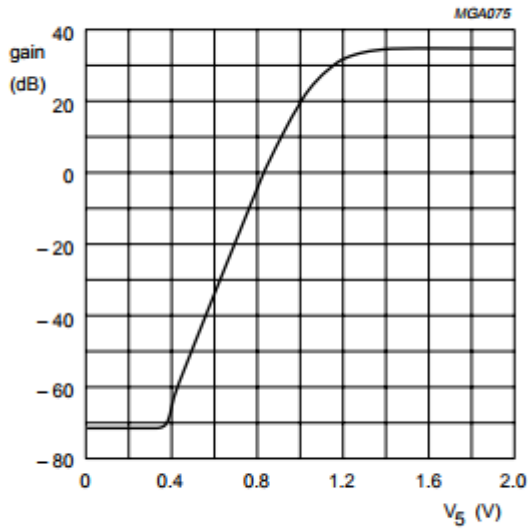

Fig.3 Gain as a function of DC volume control.

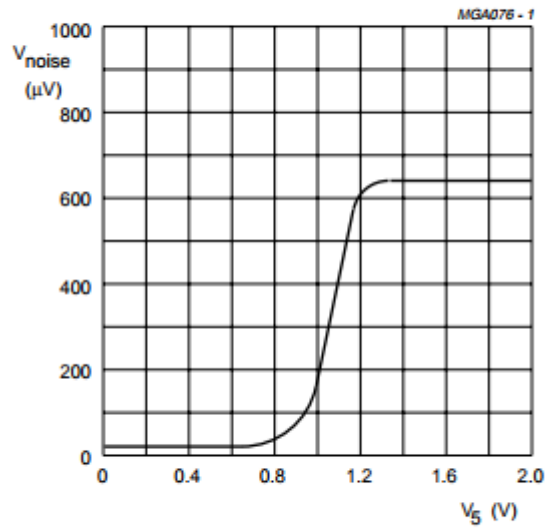

Fig.4 Noise output voltage as a function of DC volume control.

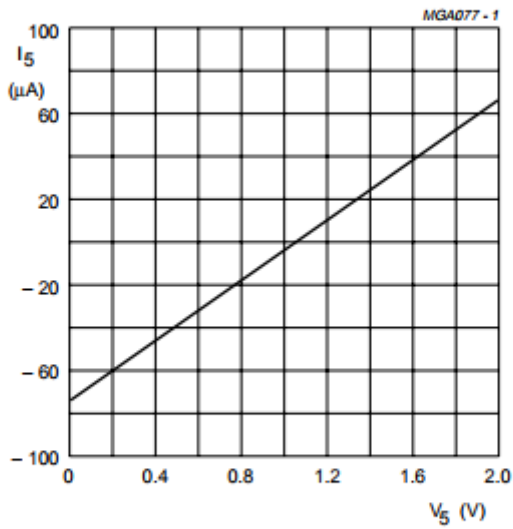

Fig.5 Control current as a function of DC volume control.

APPLICATION INFORMATION

