

SINGLE-PHASE BRIDGE RECTIFIER
RS401 THRU RS407

VOLTAGE RANGE 50 to 1000 Volts
CURRENT 4.0 Amperes

FEATURES

- Low cost
- This series is UL recognized under component index , file number E127707
- High forward surge current capability
- Ideal for printed circuit board
- High temperature soldering guaranteed: 260°C/10 second, 0.375" (9.5mm) lead length at 5 lbs. (2.3kg) tension.

MECHANICAL DATA

- Case: Transfer molded plastic
- Terminal: Lead solderable per MIL-STD-202E method 208C
- Mounting: Any
- Weight: 0.22 ounce, 6.21 gram

RS-4

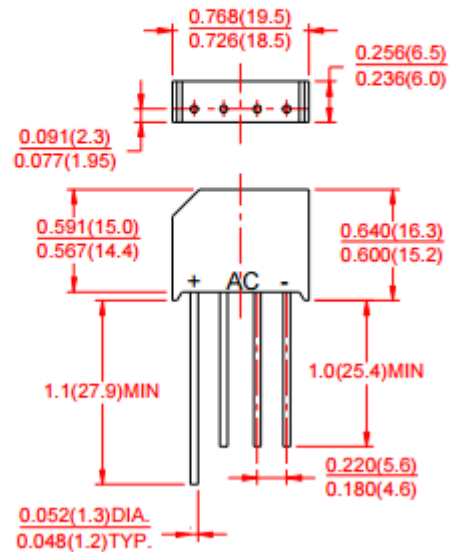

Dimensions in inches and (millimeters)

MAXIMUM RATINGS AND ELECTRICAL CHARACTERISTICS

Ratings at 25°C ambient temperature unless otherwise specified.
 Single phase, half wave, 60Hz, resistive or inductive load.
 For capacitive load derate current by 20%.

	SYMBOLS	RS401	RS402	RS403	RS404	RS405	RS406	RS407	UNITS
Maximum Repetitive Peak Reverse Voltage	V_{RRM}	50	100	200	400	600	800	1000	Volts
Maximum RMS Voltage	V_{RMS}	35	70	140	280	420	560	700	Volts
Maximum DC Blocking Voltage	V_{DC}	50	100	200	400	600	800	1000	Volts
Maximum Average Forward Rectified Output Current, at	$T_C=50\text{ }^\circ\text{C}$ (Note 2)	4.0							Amps
	$T_A=50\text{ }^\circ\text{C}$ (Note 3)	3.0							
Peak Forward Surge Current 8.3ms single half sine-wave superimposed on rated load (JEDEC Method)	I_{FSM}	150							Amps
Rating for Fusing ($t < 8.3\text{ms}$)	I^2t	93							A^2s
Maximum Instantaneous Forward Voltage Drop per bridge element at 4.0A	V_F	1.0							Volts
Maximum DC Reverse Current at rated DC blocking voltage per element	$T_A=25\text{ }^\circ\text{C}$	10							μAmps
	$T_A=100\text{ }^\circ\text{C}$	1.0							mAmps
Typical Junction Capacitance (Note 1)	C_J	55							pF
Typical Thermal Resistance (Note 2)	$R_{\theta JA}$	20							$^\circ\text{C/W}$
Operating and Storage Temperature Range	T_J, T_{STG}	-65 to +150							$^\circ\text{C}$

NOTES:

1. Measured at 1.0 MHz and applied reverse voltage of 4.0 Volts.
2. Unit mounted on 3.0"x3.0"x0.11" thick (7.5x7.5x0.3 cm) Al. plate.
3. P.C. Board mount with 0.5"x0.5" (12x12cm) copper pads 0.375" (9.5mm) lead length

RATINGS AND CHARACTERISTIC CURVES RS401 THRU RS407

FIG.1-DERATING CURVE FOR OUTPUT RECTIFIED CURRENT

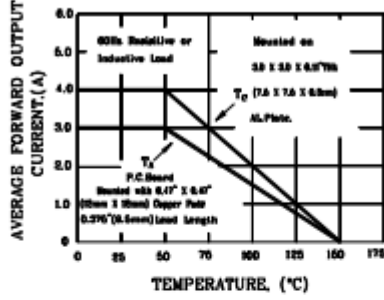

FIG.2-MAXIMUM NON-REPETITIVE PEAK FORWARD SURGE CURRENT PER ELEMENT

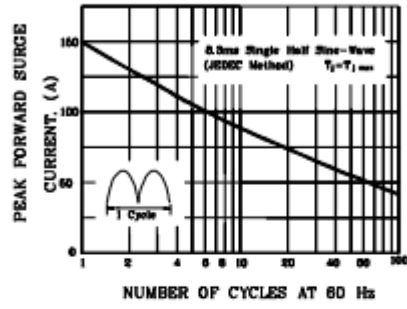

FIG.3-TYPICAL FORWARD CHARACTERISTICS PER BRIDGE ELEMENT

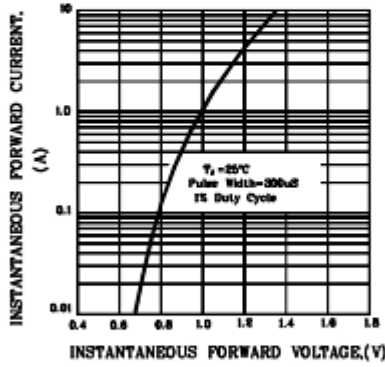

FIG.4-TYPICAL REVERSE CHARACTERISTICS PER BRIDGE ELEMENT

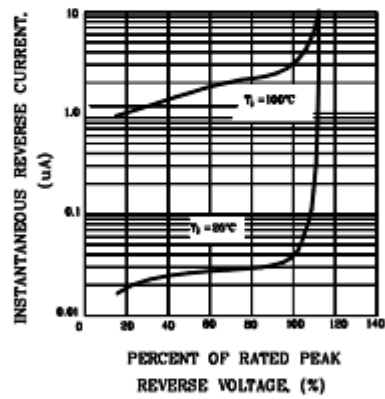

FIG.5-TYPICAL JUNCTION CAPACITANCE PER BRIDGE ELEMENT

