

## DIP 14 SERIES REED RELAYS

**MSS2 ■ MSS7 ■ PRMA ■ DSS7 ■ PRME ■ MVS2 ■ MVS7**



### DESCRIPTION

SRC Device's epoxy molded DIP 14 Series offers a variety of contacts and schematics to meet the needs of a wide range of applications. It features the MVS2/MVS7 models designed for high reliability. The MSS2/MSS7 DIPs are 1-Form-A relays equipped with the MYAD® all-position mounting switch. With switching up to 50 Watts and a 4000V isolation option, the DIP 14 Series is a relay package that allows for automatic insertion directly on PCBs as well as insertion into standard 14 Pin DIP sockets.

### FEATURES

- All position mercury contacts on some models
- Stable contact resistance over life
- 4000 Vac input-output isolation
- Bounce free operation
- High insulation resistance
- Switching speed of 300Hz
- Long life > 1 billion operations
- Epoxy molded for automatic board processing
- FCC68 compatible (MSS2 & MSS7)

### APPLICATIONS

- Automatic test equipment
- Process control
- Industrial
- Telecom
- Datacom
- High-end security systems
- Signaling
- Metering

### APPROVALS

- UL approval (DSS7 & PRMA)
- EN 60950 certified (MVS7, DSS7 & MSS7)
- CSA approval (PRMA)

### RATINGS (@ 25° C)

Parameter	Min	Typ	Max	Unit
Switching Voltage				
PRMA/PRME/DSS7			200	Volts
PRMA Form C			100	Volts
MSS2/MSS7			500	Volts
MVS2/MVS7			1000	Volts
Switching Current				
PRMA/PRME/DSS7			0.5	Amps
PRMA Form C			0.25	Amps
MSS2/MSS7/MVS2/MVS7			2	Amps
Carry Current				
PRMA/PRME/DSS7			2	Amps
PRMA Form C			0.4	Amps
MSS2/MSS7			3	Amps
MVS2/MVS7			3	Amps
Switching Frequency				
PRMA/PRME/DSS7			500	Hz
PRMA Form C			50	Hz
MSS2/MSS7/MVS2/MVS7			200	Hz
Contact Resistance				
PRMA/PRME/DSS7			150	mΩ
PRMA Form C			200	mΩ
MSS2/MSS7/MVS2/MVS7			100	mΩ

(See detailed specifications for more information.)

## SPECIFICATIONS

All parameters are at 25°C unless otherwise stated.  
Operate voltage, release voltage, and coil resistance will change approximately 0.4%/°C as ambient temperature varies.

**PRMA**  
Molded 8 Pin  
Form-C  
Dry Reed

**PRMA**  
Molded 8 Pin  
Form-A&B  
Dry Reed

PARAMETER	CONDITIONS	SYMBOL	MIN	TYP	MAX	MIN	TYP	MAX	UNITS
<b>Contact Ratings</b>									
Switching Voltage	Max DC/PeakAC Resistive	V <sub>L</sub>	-		100	-	-	200	Volts
Switching Current	Max DC/PeakAC Resistive	I <sub>L</sub>	-		0.25	-	-	0.5	Amps
Carry Current	Max DC/PeakAC Resistive	I <sub>c</sub>	-		0.4	-	-	2	Amps
Contact Rating	Max DC/PeakAC Resistive		-		3	-	-	10	Watts
Life Expectancy	Signal Level 1.0V 10mA Related Loads <sup>(1)</sup>		-	20	-	300	500	-	x10 <sup>6</sup> Ops
Static Contact Resistance	50mV, 10mA	CR	-		200	-	-	150	mΩ
Dynamic Contact Resistance	.5V, 50mA at 100Hz, 1.5 msec	DCR	-	N/A	-	-	N/A	-	mΩ
Contact Material			-	Rh	-	-	Ru	-	
<b>Relay Specifications</b>									
Insulation Resistance	Between all isolated pins at 100V, 25°C, 40% RH	IR	10 <sup>9</sup>	10 <sup>10</sup>	-	10 <sup>10</sup>	10 <sup>12</sup>	-	Ω
Capacitance	Across Open Contacts		-	2.5	3	-	0.7	1	pF
	Open Contact to Coil		-	3	3	-	1.5	2	pF
Dielectric Strength	Between Contacts		250	-	-	250	-	-	VDC/Peak AC
	Contacts to Coil	I/O	1400	-	-	1400	-	-	VDC/Peak AC
Operate Time, including bounce	At Nominal Coil Voltage 10Hz Square Wave	T <sub>OP</sub>	-	1.5	2	-	.25	0.5	ms
Release Time	Zener-Diode Suppression	T <sub>REL</sub>	-	1.5	3	-	.25	0.5	ms
<b>Environmental Ratings</b>									
Storage Temperature		T <sub>A</sub>	-40	-	+105	-40	-	+105	°C
Operating Temperature		T <sub>O</sub>	-40	-	+80	-40	-	+80	°C
Soldering Temperature	Applied to pins, 5 sec. max.		-	260	-	-	-	260	°C
Vibration Resistance <sup>(2)</sup> (Survival)	10 Hz - 500 Hz for PRMA Form A&B 5Hz - 500Hz for PRMA Form C	G	-	-	10	-	-	20	Gs
Shock Resistance (Survival)	11±1ms, 1/2 Sine Wave	S	-	-	50	-	-	100	Gs
Weight			-	1.5	-	-	1.5	-	grams

<sup>(1)</sup> Refer to life graphs

<sup>(2)</sup> Use caution not to exceed vibration resistance limits while ultrasonically cleaning relays with DYAD switches. Contact SRC Devices Engineering for more details/recommendations.

## COIL SPECIFICATIONS

	Contact Form	Coil Voltage			Coil Resistance			Operate Voltage			Release Voltage			Nominal Input Power		
		Volts			Ω			Volts			Volt			mW		
Units																
Conditions					+/- 10% (25°C)			Must operate by (25°C)			Must release by (25°C)					
Part #		Min	Typ	Max	Min	Typ	Max	Min	Typ	Max	Min	Typ	Max	Min	Typ	Max
MSS2 1A05	1-Form-A		5	11	126	140	154			3.75	0.5					179
MSS2 1A12	1-Form-A		12	21	450	500	550			9	1					288
MSS2 1A24	1-Form-A		24	44	1935	2150	2365			18	2					268
MSS7 1A05	1-Form-A		5	11	126	140	154			3.75	0.5					179
MSS7 1A12	1-Form-A		12	21	450	500	550			9	1					288
MSS7 1A24	1-Form-A		24	43	1935	2150	2365			18	2					268
PRMA 1A05	1-Form-A		5	21	450	500	550			3.75	0.8					50
PRMA 1A12	1-Form-A		12	30	900	1000	1100			9	1					144
PRMA 1A24	1-Form-A		24	44	1935	2150	2365			18	2					268
PRMA 1B05	1-Form-B		5	6	450	500	550			3.75	0.8					50
PRMA 1B12	1-Form-B		12	14.5	900	1000	1100			9	1					144
PRMA 1B24	1-Form-B		24	29	1935	2150	2365			18	2					268
PRMA 1C05	1-Form-C		5	12	180	200	220			3.75	0.8					125
PRMA 1C12	1-Form-C		12	18	450	500	550			9	1					288
PRMA 1C24	1-Form-C		24	32	1935	2150	2365			18	2					268

PRMA 2A05	2-Form-A	5	11	126	140	154	3.75	0.8	179
PRMA 2A12	2-Form-A	12	21	450	500	550	9	1	288
PRMA 2A24	2-Form-A	24	44	1935	2150	2365	18	2	268
PRMA 10037	1-Form-A	5	15	342	380	418	3.75	0.8	66
PRMA 10038	1-Form-A	12	19	477	530	583	9	1	272
PRMA 10039	1-Form-A	24	32	1800	2000	2200	18	2	288
DSS7 1A05	1-Form-A	5	21	450	500	550	3.75	0.8	50
DSS7 1A12	1-Form-A	12	30	900	1000	1100	9	1	144
DSS7 1A24	1-Form-A	24	44	1935	2150	2365	18	2	268
PRME 25005	1-Form-A	5	19	450	500	550	3.8	0.8	50
PRME 15005	1-Form-A	5	15	342	380	418	3.5	1	66
PRME 15002	1-Form-A	12	19	477	530	583	8	1	272
PRME 15003	1-Form-A	24	32	1800	2000	2200	16	2	288
MVS2 1A05(A,B)	1-Form-A	5	7	94.5	105	116	3.75	0.5	238
MVS2 1A12(A,B)	1-Form-A	12	15	450	500	550	9	1	288
MVS2 1A24(A,B)	1-Form-A	24	30	1935	2150	2365	18	2	268
MVS7 1A05(S)	1-Form-A	5	7	94.5	105	116	3.75	0.5	238
MVS7 1A12(S)	1-Form-A	12	15	450	500	550	9	1	288
MVS7 1A24(S)	1-Form-A	24	30	1935	2150	2365	18	2	268

## PERFORMANCE GRAPHS

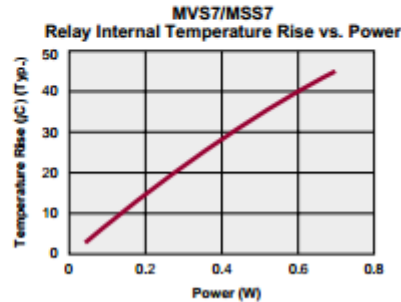
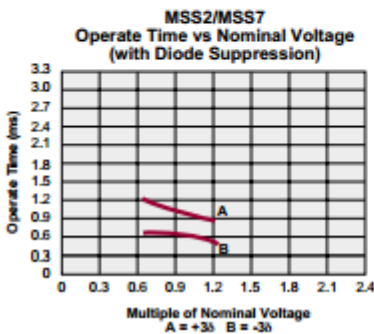
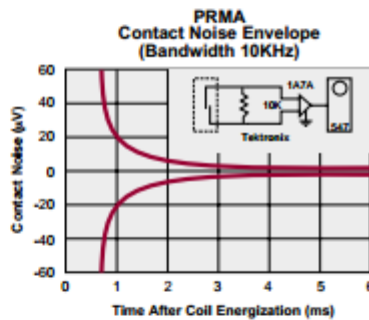
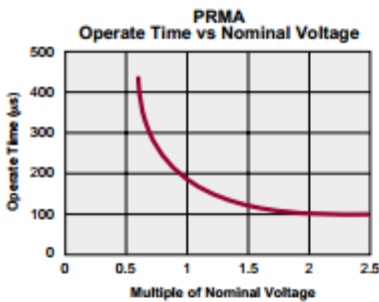
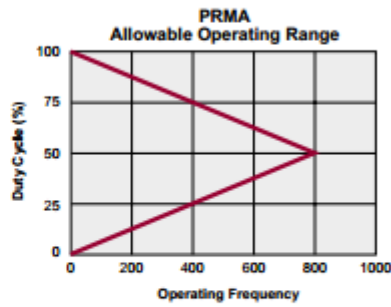
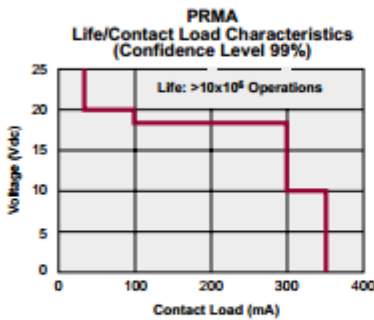

**DIMENSIONS**  
mm  
(inches)

# MECHANICAL DIMENSIONS

## PRMA

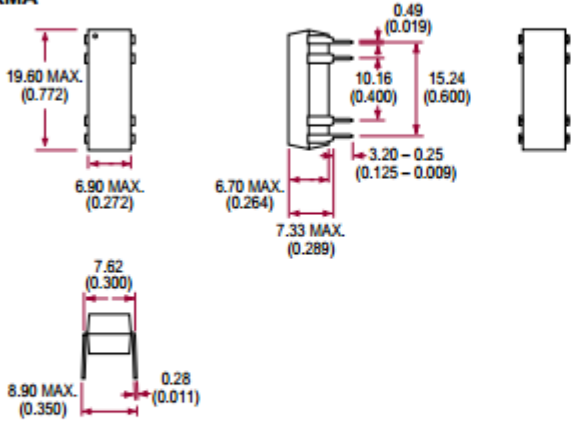

## PRMA 1A

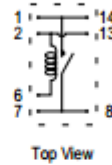

Options:  
Diode - pin #2 is positive  
Electrostatic shield - pin 9

## PRMA 1B

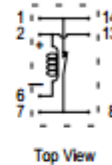

Options:  
Diode - pin #2 is positive  
Electrostatic shield - pin 9

## PRMA 1C

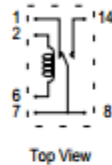

Options:  
Diode - pin #2 is positive  
Electrostatic shield - pin 9

## PRMA 2A

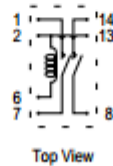

Options:  
Diode - pin #2 is positive  
Electrostatic shield - pin 9

## PRMA 10037/10038/10039

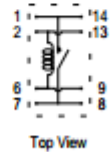

Options:  
Diode - pin #2 is positive  
Electrostatic shield - pin 9

## MVS2/MSS2

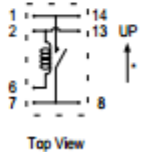

\* MVS2 only must be mounted vertically with pin #1 UP.

